



863-967-0651

ating F
ating I
Emergency
CE

1999
fuel Bar
on 4 jacks
model 230
Serial FNC3521
D-905-
Cabota 396

230

2 - WHEEL DRIVE TURF UNIT

Starting Serial No. 3001

Owner / Operator's Manual



CAUTION

Avoid injuries. Read and understand Operator's manual before operating tractor or equipment. It contains instructions for safe operation.

Form # 09-380



CAUTION

- READ AND UNDERSTAND OPERATORS MANUAL BEFORE OPERATING OR SERVICING.
- OBEY ALL SAFETY INSTRUCTIONS. FAILURE TO DO SO MAY RESULT IN INJURY TO YOU OR OTHERS.
- BE SURE MACHINE IS IN SAFE OPERATING CONDITION BEFORE USE.
- INSPECT MACHINE DAILY. REPLACE ALL WORN OR DAMAGED PARTS.
- KEEP ALL GUARDS AND SHIELDS IN PLACE.
- CHECK OPERATION OF ALL SAFETY INTERLOCK SWITCHES DAILY.
- DO NOT OVERRIDE INTERLOCK SYSTEM, IT IS FOR YOUR PROTECTION.
- DO NOT ALLOW MINORS OR UNTRAINED TO OPERATE MACHINE.
- KEEP PEOPLE AND PETS A SAFE DISTANCE AWAY FROM MACHINE USING POWER DRIVEN ATTACHMENTS. INJURY COULD RESULT FROM FLYING DEBRIS.

Date of Purchase: Month _____ Day _____ Year _____

Dealer Name _____ Phone _____

Serial Number _____

Model Number _____

ALWAYS GIVE MODEL AND SERIAL NUMBER WHEN ORDERING SERVICE PARTS

STEINER

STEINER TURF EQUIPMENT, INC.
289 N. Kurzen Rd., P.O. Box 504
Dalton, Ohio 44618

Telephone: (330) 828-0200
FAX: (330) 828-1008

TABLE OF CONTENTS

<u>INTRODUCTION</u>	<u>SECTION 1</u>	<u>Page</u>
Introduction		1-1
Specifications		1-2
<u>SAFETY</u>	<u>SECTION 2</u>	
General Safety		2-1
Safety Practices		2-2
Safety Decals		2-4
<u>PRE-START INSTRUCTIONS</u>	<u>SECTION 3</u>	
Starting Instructions		3-1
Fuels and Oils		3-2
<u>OPERATION</u>	<u>SECTION 4</u>	
Controls		4-1
Operating Precautions		4-3
Operating Instructions		4-3
Emergency Moving		4-7
<u>SERVICE</u>	<u>SECTION 5</u>	
Service Chart		5-1
Capacities		5-3
Oil Change Procedures		5-4
Service Tips		5-5
Adjustments		5-6
Hydraulic System		5-7
Frame		5-8
Wheels and Tires		5-9
Electric Clutch		5-10
Trouble Shooting Chart		5-11
<u>ASSEMBLY</u>	<u>SECTION 7</u>	
Assembly Instructions		7-1
Warranty		last page



The Steiner 230 is designed to offer a new measure of operator control and power efficiency. From the low mid-frame seating to the finger-tip traction booster control, all blend together to form a sturdy power unit that stands up to tough chores and yet is fun to drive!

The Model 230 provides a low center of gravity for a stable, turf-hugging machine. The operator sits mid-frame for comfort and safety with complete control over front mounted attachments. Infinite speed control is provided by the hydrostatic transmission. Constant traction is maximized through finger-tip selection of hydraulic weight transfer. And a differential lock insures even traction when mowing through wet conditions, along sidehills or other difficult terrain.

SPECIFICATIONS

Dimensions:

Overall Width	-----	58"
Overall Length	-----	82"
Overall Height	-----	45"
Wheelbase	-----	50"
Inside Turning Radius	-----	14"
Weight	-----	1290 lbs. (Linamar)
		1360 lbs. (Kubota gas)
		1410 lbs. (Kubota diesel)

Engine:

Standard	-----	Linamar LX790
		20 HP air-cooled
Optional	-----	Kubota WG750-E Gas
		liquid-cooled 21 HP
Optional	-----	Kubota D905-B Diesel
		liquid-cooled 23.5 HP

Drive Train:

Transmission	-----	Sundstrand Hydrostatic
		Piston pump/motor
Transaxle	-----	Peerless 2600
		2-speed w/diff lock
Speeds	-----	Forward and Reverse
		0-10 MPH (high)
		0-5 MPH (low)
Steering	-----	Hydraulic power steering
Brakes	-----	Individual wheel drum brakes

Tires:

Drive	-----	24 x 12 -12, super turf, 2 ply
Rear	-----	18 x 8.5-8 Ribbed, 4 ply

Electrical:

Starting	-----	12 volt, Key switch
Battery	-----	12 volt, Group 26

Fuel System:

Tank capacity	-----	6 Gallons (US)
Fuel Pump	-----	Diaphragm (Linamar)
		Electric (Kubota)



BE ALERT!

ATTENTION:

This symbol identifies potential health and safety hazards. It marks safety precautions. Your safety and the safety of others is involved.

SIGNAL WORD DEFINITIONS



Indicates an imminently hazardous situation which, if not avoided, will result in death or serious injury. This signal word is limited to the most extreme cases.



Indicates a potentially hazardous situation which, if not avoided, could result in death or serious injury.



Indicates a potentially hazardous situation which, if not avoided, may result in minor or moderate injury and/or property damage. It may also be used to alert against unsafe practices.

CALIFORNIA Proposition 65 Warning

Diesel engine exhaust and some of its constituents are known to the State of California to cause cancer, birth defects and other reproductive harm.

GENERAL SAFETY

Read and understand the owner's manual, before attempting to operate this machine.

Operate all controls from the operator's seat, (if so equipped). NO RIDERS.

Keep all shields in place and safety switches adjusted properly.

Do not leave equipment unattended. STOP the engine and remove the key (if so equipped).

Do not allow minors or the inexperienced to operate this machine.

Keep people and pets a safe distance away from machines using power driven attachments. Injury could result from flying debris.

OPERATING SAFETY

STOP ENGINE to install drive belts or make adjustments. Do not attempt to work on unit or any attachments with engine running! **STOP ENGINE.**

WARNING! The tractor may coast when the engine stops. Set parking brake locks.

BEFORE LEAVING THE TRACTOR SEAT:

1. Disengage PTO Drive.
2. Set PARK Brake Locks.
3. Stop Engine.

DO NOT TOW! Serious damage to the hydraulic system will result. See Section 4.7 for emergency moving instructions.



WARNING

The engine exhaust from this product contains chemicals known to the State of California to cause cancer, birth defects or other reproductive harm.

IMPORTANT**Safety Practices For Commercial
Turf Care Equipment****I Training**

1. Read the Operator's manual and other training material. If the operator(s) or mechanic(s) can not read English it is the owner's responsibility to explain this manual to them.
2. Become familiar with the safe operation of the equipment, operator controls, and safety signs.
3. All operators and mechanics should be trained. The owner is responsible for training the users.
4. Never let children or untrained people operate or service the equipment. Local regulations may restrict the age of the operator.
5. The owner/user can prevent and is responsible for accidents or injuries occurring to themselves, other people, or property.

II Preparation

1. Evaluate the terrain to determine what accessories and attachments are needed to properly and safely perform the job. Only use accessories and attachments approved by the manufacturer.
2. Wear appropriate clothing including hard hat, safety glasses, and ear protection. Long hair, loose clothing, or jewelry may get tangled in moving parts.
3. Inspect the area where the equipment is to be used and remove all objects such as rocks, toys, and wire which can be thrown by the machine.
4. Use extra care when handling gasoline and other fuels. They are flammable and the vapors are explosive.
 - a. Use only an approved container.
 - b. Never remove gas cap or add fuel with engine running. Allow engine to cool before refueling. Do not smoke.
 - c. Never refuel or drain the machine indoors.
5. Check that operator's presence controls, safety switches, and shields are attached and functioning properly.

III Operation**⚠ WARNING**

Slopes are a major factor related to loss-of-control and tip-over accidents, which can result in severe injury or death. All slopes require extra caution.

1. Never run an engine in an enclosed area.
2. Only operate in good light, keeping away from holes and hidden hazards.
3. Be sure all drives are in neutral and parking brake is set before starting engine. Only start engine from the operator's position. Use seat belts if provided.
4. Slow down and use extra care on hillsides. Be sure to travel in the recommended directions on hillsides. Turf conditions can affect the machines stability. Use caution when operating near drop-offs.
5. Follow the manufacturers recommendations for wheel weights or counterweights to improve stability. (See Section 4, page 4-3)
6. Slow down and use caution when making turns and when changing directions on slopes.
7. Never raise mower deck with the blades running.
8. Never operate with guards not securely in place. Be sure all interlocks are attached, adjusted properly, and functioning properly.
9. Never operate mower with the discharge deflector raised, removed or altered.
10. Do not change the engine governor setting or overspeed the engine.
11. Never leave a running machine unattended.
12. Stop on level ground, lower implements, disengage drives, engage parking brake, and shut off engine before leaving the operator's position for any reason including unclogging the chute.
13. Stop equipment and inspect blades after striking objects or if an abnormal vibration occurs. Make necessary repairs before resuming operations.
14. Keep hands and feet away from cutting units.
15. Look behind and down before backing up to be sure of a clear path.

SAFETY

16. Never carry passengers and keep pets and bystanders away.
17. Slow down and use caution when making turns and crossing roads and sidewalks. Stop blades if not mowing.
18. Be aware of the mower discharge direction and do not point it at anyone.
19. Do not operate the machine under the influence of alcohol or drugs.
20. Use care when loading or unloading the machine into a trailer or truck.
21. Use care when approaching blind corners, shrubs, trees, or other objects that may obscure vision.

section 2

IV Maintenance and storage

1. Disengage drives, lower implement, set parking brake, stop engine and remove key. Wait for all movement to stop before adjusting, cleaning, or repairing.
2. Clean grass and debris from cutting units, drives, mufflers, and engine to help prevent fires. Clean up oil or fuel spillage.
3. Let engine cool before storing and do not store near flame.
4. Shut off fuel while storing or transporting. Do not store fuel near flames or drain indoors.
5. Park machine on level ground. Never allow untrained personnel to service machine.
6. Use jack stands to support components when required.
7. Carefully release pressure from components with stored energy. (hydraulic accumulator)
8. Disconnect battery or remove spark plug wire before making any repairs. Disconnect the negative terminal first and the positive last. Reconnect positive first and negative last.
9. Use care when checking or changing blades. Wrap the blade(s) or wear gloves, and use caution when servicing them. Only replace blades. Never straighten or weld them.
10. Keep hands and feet away from moving parts. If possible, do not make adjustments with the engine running.
11. Charge batteries in an open well ventilated area, away from sparks or flames. Unplug charger before connecting or disconnecting from battery. Wear protective clothing and use insulated tools.
12. Keep all parts in good working condition and all hardware tightened. Replace all worn or damaged safety decals.

 **WARNING** 

**BEFORE OPERATING THIS MACHINE
READ AND UNDERSTAND
THE OPERATOR'S MANUAL.
KEEP ALL SHIELDS IN PLACE
AND FOLLOW ALL SAFETY RULES.**

00-093

Location:

On dash



 **WARNING** 

**KEEP HANDS AWAY FROM BELT
WHILE ENGINE IS RUNNING.**

00-025

Location:

On front light panel.

 **DANGER** 

**HYDRAULIC PRESSURE MAY BE PRESENT
WITH THE ENGINE STOPPED. THIS UNIT IS
EQUIPPED WITH A HYDRAULIC ACCUMULATOR
FOR WEIGHT TRANSFER FROM FRONT
MOUNTED ATTACHMENTS.**

**STOP ENGINE AND DECREASE ACCUMULATOR
PRESSURE TO "0" PSI BEFORE ATTEMPTING
TO REMOVE FRONT MOUNTED ATTACHMENTS
OR SERVICE UNIT.**

**FAILURE TO DECREASE ACCUMULATOR
PRESSURE MAY RESULT IN SERIOUS INJURY.**

00-261

Location:

Right Front Fender

 **CAUTION** 

DO NOT TOW!
Serious damage to hydraulic system will result.
For emergency moving stalled unit, see Operator's Manual.
**SLOW DOWN ON ROUGH, UNEVEN OR
STEEP TERRAIN.**

00-200

Location:

Center Console

PRE-START INSTRUCTIONS

section 3

BEFORE STARTING:

1. READ SAFETY DECALS
2. Check engine and transaxle oil levels.
3. Check coolant level. (Kubota)
4. Visually check tires.
5. Visually check for loose or missing parts or bolts.
6. Fill with clean fuel.

STARTING INSTRUCTIONS:

1. Safety switch requires Forward - Reverse pedal to be in NEUTRAL and PTO to be OFF for engine to start.
2. Open throttle approximately one-fourth of its travel.
3. GASOLINE ENGINES: Pull choke until engine starts.
DIESEL ENGINE: Turn key counter-clockwise to "preheat" until indicator light goes off. No "preheat" is required when engine is warm.
4. Turn key clockwise to start engine.
5. Warm up engine at medium speed. Push choke in on gasoline engine as engine warms up.
6. In cold weather, allow the hydraulic oil to warm up a few minutes at medium engine speed before using tractor.

 **CAUTION**

NEVER USE ETHER AS A STARTING AID OR SEVERE DAMAGE TO ENGINE MAY OCCUR.

 **DANGER**

NEVER FILL FUEL TANK WITH ENGINE RUNNING!

SPECIFICATIONS FOR FUELS AND OILS

ENGINE OIL

Fill the crankcase with oil that meets API service designation SF, SF/CC, or SF/CD. Do not mix brands or grades of oil. Recommended weights for expected temperatures are:

LINAMAR ENGINES:

32° F (0° C) and higher.....SAE 30
0° F to 80° F (-18° C to 27° C).....SAE 10W30
or SAE 10W40
-20° F to 50° F (-28° C to 10° C)....SAE 5W--30

KUBOTA DIESEL ENGINES:

77° F (25° C) and higher.....SAE 30
or SAE10W30
32° F to 77° F (0° C to 25° C).....SAE 20
or SAE10W30
Below 32° F (0° C).....SAE 10W
or SAE10W30

KUBOTA GAS ENGINES

77° F (25° C) and higher.....SAE 30
or SAE 10W30
32° F to 77° F (0° C to 25° C).....SAE 20
or SAE 10W30
10° F to 32° F (-12° C to 0° C)....SAE 10W
or SAE 10W30
Below 10° F (-12° C).....SAE 5W30

FUEL

GASOLINE: Use clean, fresh, regular or unleaded fuel. Use of unleaded fuel results in less maintenance.

DIESEL: Use clean, fresh No. #2 diesel fuel. In extreme cold temperatures No. #1 diesel fuel may be used. Do not use kerosene or damage to engine may result. Refer to engine manual for fuel bleeding instructions.

TRANSAXLE HYDRAULIC OIL

Fill transaxle to the safe range with approved hydraulic oil. Use only Steiner Trans-Hydraulic Oil or Texas Refinery Corp. 6440 Universal Torque Fluid. Do not use automatic transmission fluid, motor oil, or any other type of hydraulic oil.

NOTE:

THE USE OF ANY OIL OTHER THAN STEINER TRANS-HYDRAULIC OIL OR TEXAS REFINERY CORP. 6440 UNIVERSAL TORQUE FLUID IS NOT RECOMMENDED. IF A SUBSTITUTE OIL CAUSES OR SUBSTANTIALLY CONTRIBUTES TO A FAILURE, THAT FAILURE MAY NOT BE COVERED BY WARRANTY.

CAUTION

BE ALERT! STOP RUNNING THE UNIT AT THE FIRST SIGN OF ANY ABNORMAL HYDRAULIC FUNCTION. SERIOUS DAMAGE TO THE HYDRAULIC SYSTEM CAN RESULT!

COOLANT

Fill coolant system with a mixture of one part Permanent Anti-freeze and one part water.

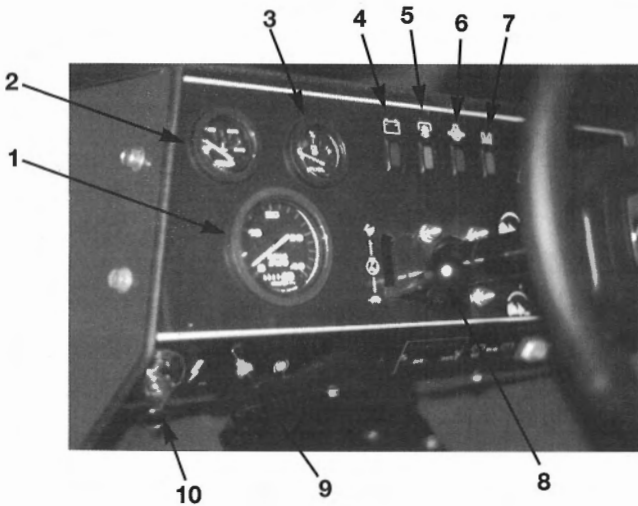

Photo 1 - Controls... Dash Left Side

OPERATOR CONTROLS

1. **Tachometer and Hour Meter**
2. **Coolant Temperature Gauge** (liquid cooled units only)
Volt Meter (air cooled units only - Linamar)
3. **Fuel Gauge**
4. **Charging System Indicator Light**
5. **PTO Engaged Indicator Light**
6. **Engine Oil Pressure Indicator Light**
7. **Glow Plug Indicator Light** (diesel only)
8. **Throttle Lever**
Throttle controls engine speed.
9. **Park Brake Knob**
10. **Key Switch**
Starting and ignition

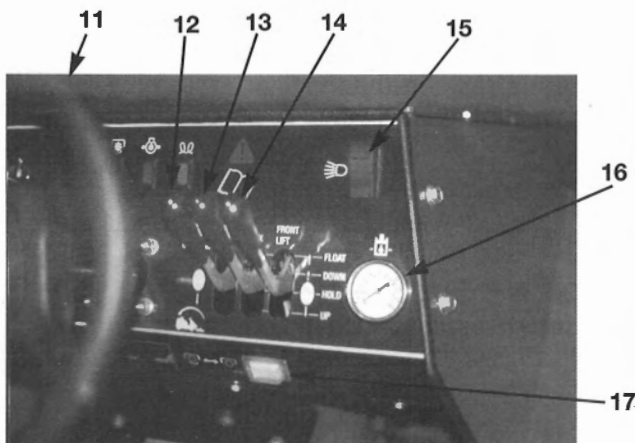
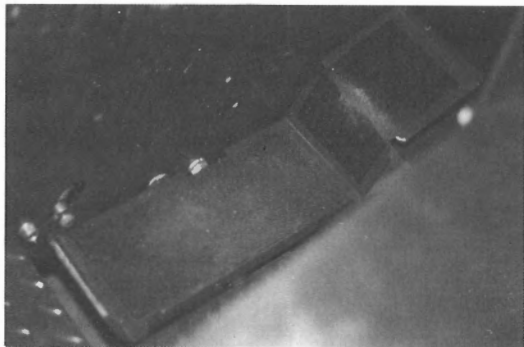
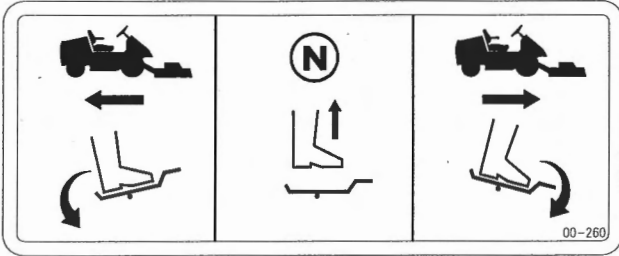
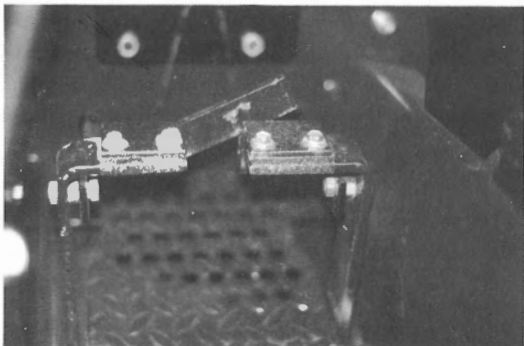

Photo 2 - Controls... Dash Right Side

11. **Power Steering**
Full power steering for easy handling.
12. **Traction Booster Valve Lever**
Set maximum traction for front mounted attachments.
13. **Auxiliary Hydraulic Lever**
Auxiliary lever controls the attachments which are connected to the auxiliary couplers.
14. **Hydraulic Front Lift Lever**
Lift lever controls front mounted implements.
Float position is provided for those attachments which require float.
15. **Light switch**
16. **Accumulator Pressure Gauge**
17. **PTO Electric Clutch Switch**
Controls Power Take Off front belt drive.
Operator must be seated for PTO to engage.



**Photo 3 - Controls...
Forward - Reverse Pedal**



**Photo 4 - Controls...
Brake Pedal Lock**

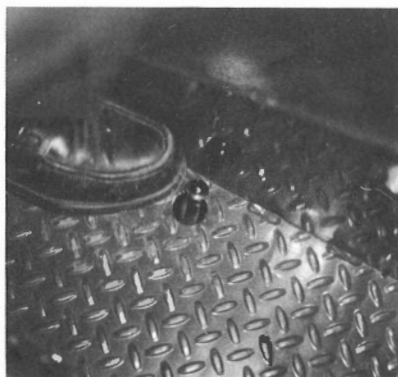

**Photo 5 - Controls...
Differential Lock**

18. Hydrostat Pedal

Single foot pedal controls forward and reverse at infinitely variable speeds.

19. Individual Wheel Brakes

Keep brakes locked together except when needed to assist in tight turns. (see Photo 4)
Use independently to assist in tight turns.
Do not use brakes for stopping except in emergency. Set park brake locks for parking.

20. Differential Lock

Locks in full 2-wheel traction to get you through the tough conditions.

OPERATING PRECAUTIONS

- Observe all Safety Decals.
- Keep all Shields in place.
- Do not allow minors or the inexperienced to operate machine. **NO RIDERS!**

CAUTION

Slow down on rough, uneven or steep terrain and for operation of power driven mounted attachments.

- Do not operate mower with other persons in the area. Irregularities in ground surface can permit foreign material to be propelled from beneath deck to cause serious injury or death.
- Before leaving operator's seat, disengage PTO, set PARK BRAKE locks and STOP ENGINE.
- Remove key from ignition if maintenance procedures are to be performed or tractor is to be left unattended.

CAUTION

Stop running the unit at the first sign of any abnormal hydraulic function. Serious damage to the hydraulic system can result.

Rear weights may be used with attachments over 120 pounds for stability. See attachment operator's manual for weight requirements.

Always remove all rear weights when front mounted attachments are removed, or when using attachments less than 120 pounds.

OPERATING INSTRUCTIONS

1. Read and understand this manual before attempting to operate this machine.
2. Check all fluid levels before starting unit.
3. Become familiar with all controls and their functions.
4. Safety switch requires the PTO switch to be in the "OFF" position and the F - R pedal in Neutral position to start engine.
5. Select desired engine speed with the throttle.
6. Vary vehicle speed with the Forward - Reverse pedal.
7. Operate mower and other similar front mounted equipment with front lift lever in "FLOAT" position. Set traction booster. (see Traction Booster Settings on page 4-4)
8. Safety seat switch requires operator to be seated when PTO is "ON" or the electric clutch will disengage and the PTO will stop.
9. Lock brake pedals together at all times except when needed to assist in tight turns. Do not use brakes to stop vehicle except in emergency. The hydrostatic transmission provides a braking action when the Forward - Reverse pedal returns to neutral.
10. Set PARK brake locks and stop engine before dismounting.
11. **DO NOT TOW!... SERIOUS DAMAGE TO HYDRAULIC SYSTEM WILL RESULT!** See page 4-7 for emergency towing instructions.
12. See the following pages for more information on specific operator controls and adjustments.



CAUTION

BE ALERT! STOP RUNNING THE UNIT AT THE FIRST SIGN OF ANY ABNORMAL HYDRAULIC FUNCTION. SERIOUS DAMAGE TO THE HYDRAULIC SYSTEM CAN RESULT!

**TRACTION BOOSTER
Weight Transfer System**

This unit is equipped with a weight transfer system. A hydraulic accumulator is the key element to the weight transfer. Pressurizing the accumulator increases the weight transfer from the front mounted implement to the tractor. It is very important to reduce the accumulator pressure before removing front mounted attachments or servicing the unit.

Setting weight transfer settings

1. Attach front mounted attachment.
2. Start engine.
3. Observe gauge on dash (See Photo 6). To increase pressure to desired setting, move the lever toward the operator (See Photo 7). To decrease pressure, move the lever away from the operator. The pressure can be increased or decreased at any time while the engine is running.
4. Set front lift lever in the "FLOAT" position.
5. If attachment floats too freely, reduce pressure. If more traction is needed, increase pressure.

NOTE:

The Weight transfer system is effective only when the front lift lever is in the "FLOAT" position.

Guidelines for pressure settings

Reel Mower	---	50 - 500 P.S.I.
Rotary Mower 48"	---	250 - 400 P.S.I.
Rotary Mower 60"	---	350 - 500 P.S.I.
Rotary Mower 72"	---	450 - 600 P.S.I.
Rotary Sweeper	---	225 - 300 P.S.I.

! DANGER

Hydraulic pressure may be present with the engine stopped. Stop engine and decrease accumulator pressure to "0" PSI before attempting to remove front mounted attachments or service unit. Failure to decrease accumulator pressure may result in serious injury.

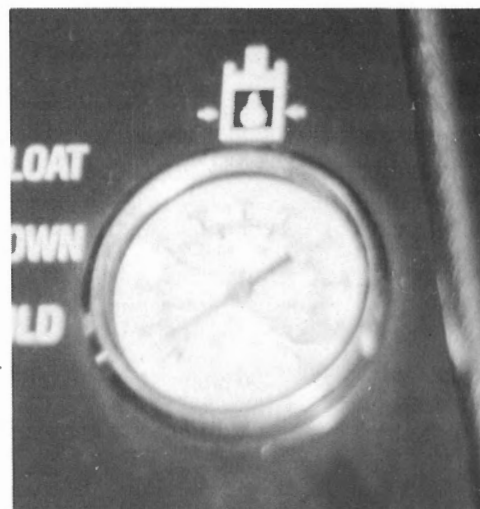

Photo 6 - Weight Transfer Pressure Gauge

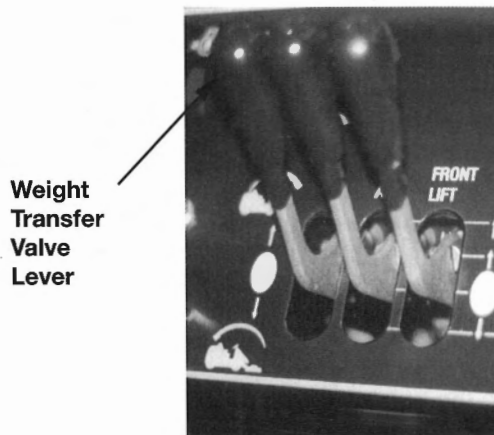

Photo 7 - Weight Transfer Valve Lever

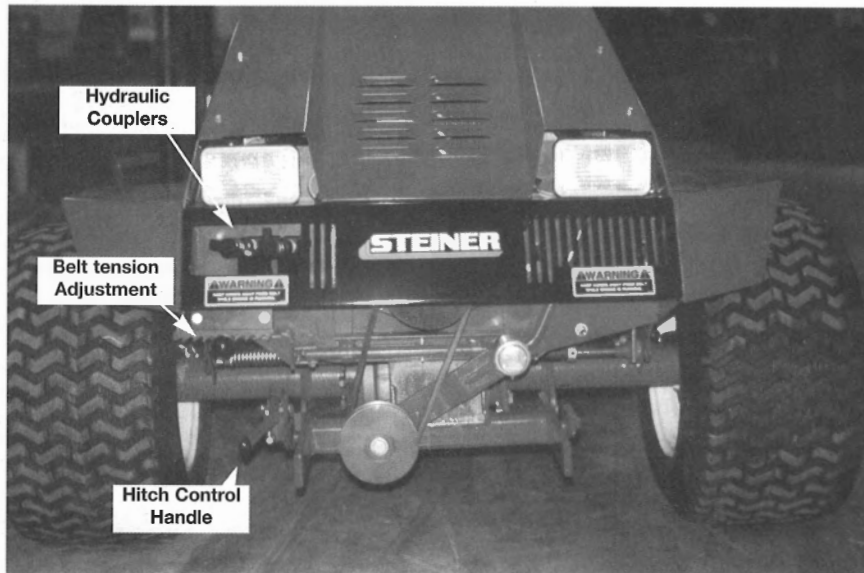

Photo 8 - PTO Electric Clutch and Front Lift

Electric Clutch Operating Instructions

Follow these steps for implement drive belt installation:

1. Place implement drive belt around the left hitch arm of the implement before attaching to the quick hitch front lift.
2. Attach the implement to the front lift. Push down on the hitch control handle to open latches. Pull up to lock latches.
3. Stop engine and release the belt tension adjustment lever by moving it as far as it will go, toward the center of the unit.
4. Install the implement drive belt on the double idler pulley.
5. Move the belt tension adjustment lever toward the outside of the unit to tighten the implement drive belt. **Proper tension is very important!** The proper setting is obtained by moving the lever one notch after all slack is taken up on the drive belts. If drive belt slips tighten one additional notch.
6. The clutch is engaged or disengaged with the rocker switch located on the dash. Engage clutch with engine at approximately 1/2 throttle.
7. **Note:** The operator must be seated for the electric clutch to operate. Do not attempt to bypass this safety device.

Front Lift

The front lift control valve is equipped with a float detent position. Always use "FLOAT" position when mowing. The traction booster is effective only in this position. There is no down pressure on the front lift, therefore attachments requiring down pressure would be ineffective.

The Quick-Hitch allows fast interchange of attachments. Push down on hitch control handle to open latches. Pull up to close and lock latches.

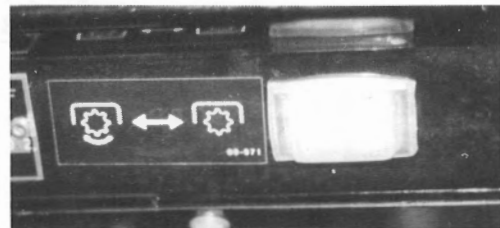

Photo 9 - PTO Electric Clutch Switch



CAUTION

DO NOT ENGAGE CLUTCH WITH ENGINE AT FULL THROTTLE. STARTING HEAVY LOADS AT FULL THROTTLE WILL SHORTEN CLUTCH LIFE.

BRAKES

Individual brakes should be locked together, except when needed for assistance in tight turns. (See Photo 4, Page 4 - 2)

Do not use brakes to stop the vehicle except in emergency. The hydrostatic transmission provides braking action when the Forward - Reverse pedal returns to neutral.

PARKING BRAKES

The wheel brakes have park locks to apply for parking.

To apply park locks.... Pull brake park lock cable knob while pressing both brake pedals.

To release park locks.... Push in brake lock cable knob and press both brake pedals to release.

See service section for brake adjustments.

WHEEL WEIGHTS

Wheel weights (Part No. 75-70465) are available for additional weight especially when mowing on slopes.

Liquid, foam, rubber, or powder ballast in tires causes excess loads on the drive train and **MAY VOID WARRANTY ON THE DRIVE TRAIN COMPONENTS** of the power unit. Modified or makeshift weights are not acceptable.

Reel mowers do require some additional weight considerations and wheel weights are recommended for mowing on slopes. Careful adjustment of the Traction Booster is necessary to allow full flotation of the reels, allowing them to follow the contour of the ground.

Rear weights may be used with attachments over 120 pounds for stability. See attachment operator's manual for weight requirements.

Always remove all rear weights when front mounted attachments are removed, or when using attachments less than 120 pounds.

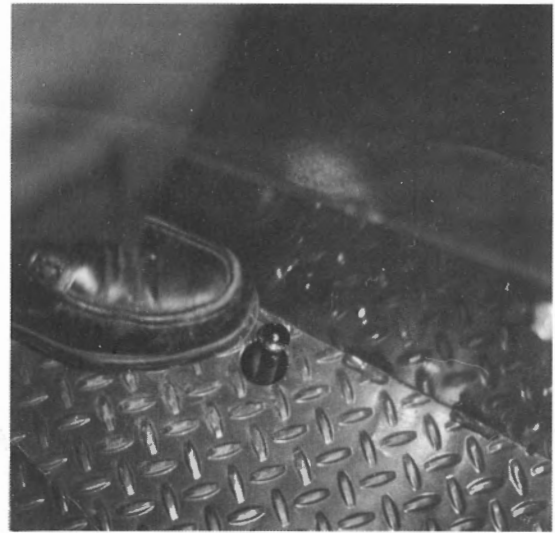

Photo 10 - Differential Lock Pedal

DIFFERENTIAL LOCK

The differential lock is standard equipment. Simply step on the pedal to engage the mechanical lock. This locks the drive wheels together for added traction. **Return Forward-Reverse foot pedal to neutral before engaging differential lock.**

CAUTION! When the differential lock is engaged, steering becomes more difficult. The unit will not turn properly until the lock is released.

The lock will release when the torque between the axles is equalized and foot is removed from the differential lock pedal.

Torque is equalized by:

- (1.) Turning slightly.
- (2.) Stopping or reversing direction of travel.
- (3.) Applying slight pressure on right or left brake pedal.

AUXILIARY HYDRAULICS

The auxiliary valve and quick couplers are standard equipment. Keep dust covers in place when couplers are not in use.

TWO SPEED TRANSAXLE SHIFT PROCEDURES

The unit is equipped with a two-speed transaxle. Normal operations will use the "HIGH" range shift position. "LOW" range position will give a finer speed control with the Forward / Reverse foot pedal for slower operations if desired. A neutral position is also available for emergency towing.

CAUTION

Whenever it is necessary to shift the transaxle into neutral or into a different range, the engine must be stopped and the parking brakes applied.

Shift Procedure

1. Remove the left access panel on the main frame.
2. Loosen and remove the 1/4 x 3/4 flange bolt "A" from the shift lever.
3. Shift the transaxle to the desired position and re-install the 1/4 x 3/4 flange bolt. Torque to 12 - 15 ft. lbs. (See the illustration at right for the shift positions).
4. Replace panel.

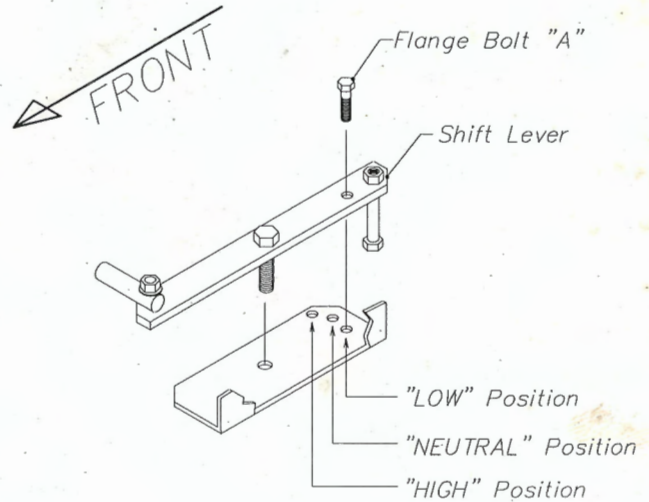

EMERGENCY MOVING A STALLED UNIT

Do Not Tow!

Transaxle shifter must be in Neutral before moving a stalled unit.

Neutral position is between "HIGH" and "LOW" position. (See shift procedure)

section 5

SERVICE

SERVICE CHART	DAILY	50 HOUR	100 HOUR	250 HOUR
Read safety decals.	X			
Check fuel level.	X			
Check engine oil level.	X			
Check transaxle oil level.	X			
Check air cleaner.	X			
Check coolant level (Kubota).	X			
Visual inspection of:				
Bolts and fittings for signs of loosening.	X			
Accumulation of dirt or foreign matter around engine restricting engine cooling.	X			
Oil leaks or belts and hoses showing signs of wear.	X			
Tires for low pressure or signs of abnormal wear.	X			
Change engine oil and filter:				
LINAMAR: Initial change at 25 hours and 50 hours thereafter. KUBOTA: Initial change at 35 hours and 100 hours thereafter.		X		X
Check air cleaner:				
Clean or replace.	X	X	X	X
Check battery water level:				
If battery is servicable, fill to cover the plates 1/4".		X	X	X
Transaxles:				
Check transaxle oil level.	X	X	X	X
<i>Use only Steiner Trans--Hydraulic Oil or Texas Refinery Corp. 6440 Universal Torque Fluid. Do not use automatic transmission fluid or motor oil.</i>				
Initial filter change at 25 hours.				
Initial hydraulic oil and filter change 50 hours.		X		
Change hydraulic oil and filter every 250 hours or annually (whichever occurs first)				X
Replace hydraulic oil filter every 250 hours or at the first sign of any abnormal hydraulic function.				X
Fuel System:				
Check or replace filter.			X	
Check Tire Pressure:				
Front - 8 to 10 lbs. Rear - 14 to 16 lbs.		X X		

SERVICE

section 5

SERVICE CHART	DAILY	50 HOUR	100 HOUR	250 HOUR ANNUAL
	Lubrication:			
Grease steering linkage, rear axle (See Fig. A).			X	
Grease front idler and idler arm (See Fig. B).			X	
Grease drive line and PTO bearings (See Fig. C).			X	
Grease foot pedal (See Fig. D).			X	
Re-pack rear wheel bearings				X
Storage:				
Drain fuel tank.				X
Maintain proper tire pressure.				X
Remove battery and maintain charge.				X
Grease exposed cylinder shafts. (See note on page 5-5 concerning electric clutch when returning unit to service after storage.)				X

LUBRICATION

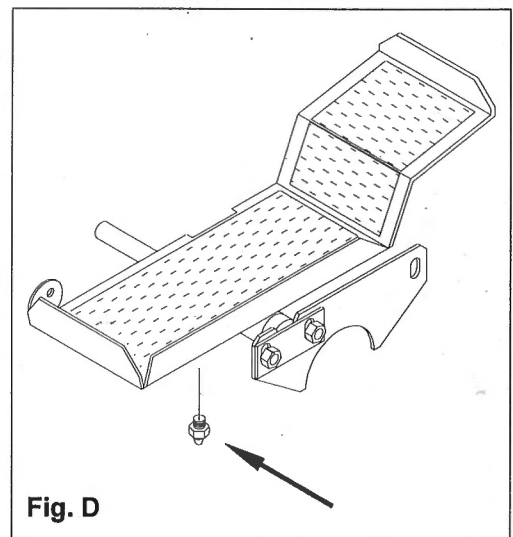
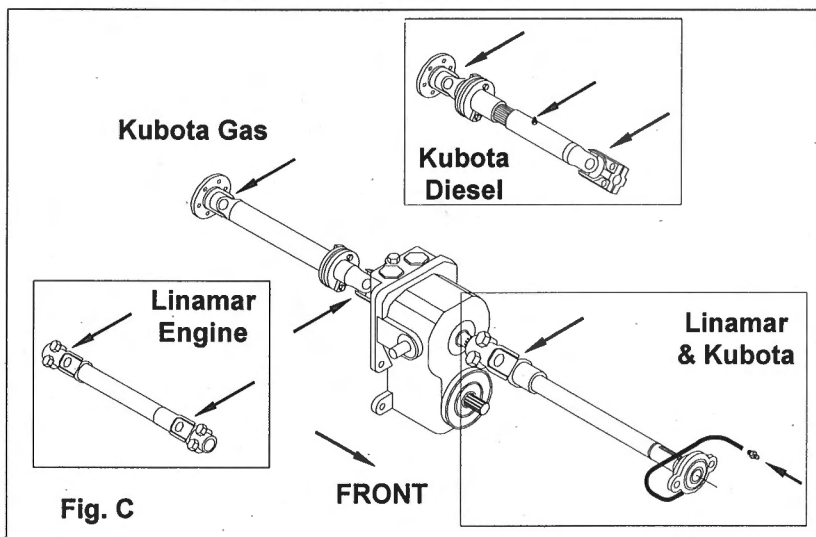
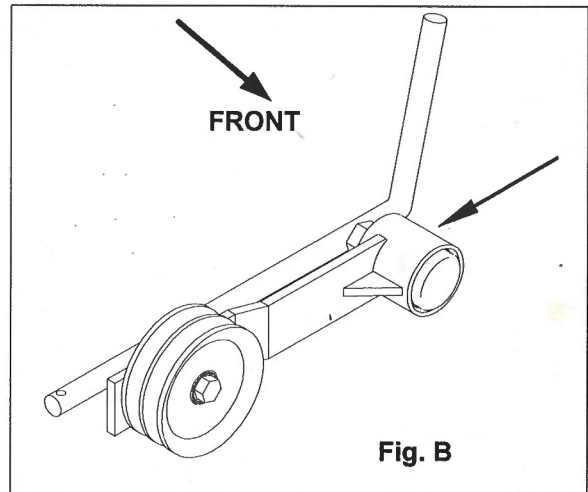
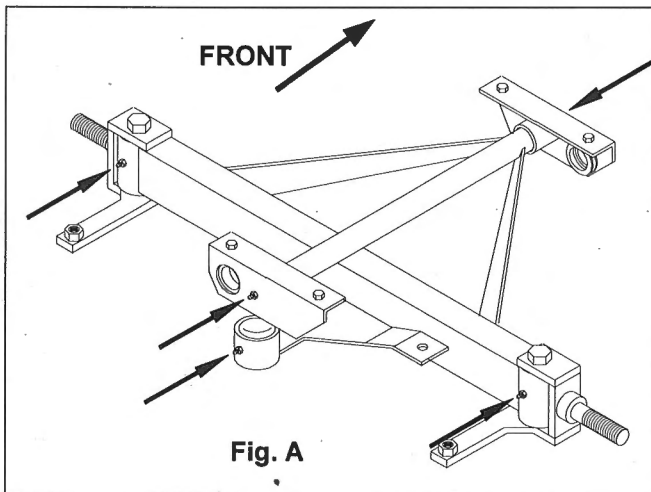

CAPACITIES CHART

<i>CAPACITY OF:</i>	<i>QUANTITY</i>
Engine Oil (Linamar)	1.8 U.S. Quarts (1.7 liter)
Engine Oil (Kubota Diesel)	5.4 U.S. Quarts (5.1 liter)
Engine Oil (Kubota Gas)	3 U.S. Quarts (2.9 liters)
Engine Coolant (Kubota Diesel)	3 U.S. Quarts (2.9 liters)
Hydraulic Oil (Transaxle)	(Approx.) 6 quarts (5.7 liters)
Fuel Tank	6 gal. (22.7 liters)

ELECTRICAL

- Do not bypass or eliminate safety devices.
- Keep all electrical connections clean and dry.
- Do not add extra electrical equipment.
- If wire replacement is necessary, replace with the same gauge and color code.
- Make certain there is a ground strap between engine and frame.
- Follow recommended jump starting procedures.
- Use only factory recommended size batteries.
- Make a periodic visual inspection of all wiring to ensure it is not damaged.
- Maintain battery by keeping terminals and top of battery clean.

ENGINE**Engine Oil Specifications and
Recommendations**

Fill the crankcase with oil that meets API service designation SF, SF/CC, or SF/CD. Do not mix brands or grades of oil.

Recommended weights for expected temperatures are listed in Section 3 PRE-START INSTRUCTIONS

ENGINE OIL AND FILTER CHANGE PROCEDURE**Linamar:**

25 hours initial;
50 hours thereafter.

Kubota:

35 hours initial;
100 hours thereafter.

1. Run engine until engine is warm for complete draining.
2. Open drain cock. (all engines)
3. Remove oil filter and wipe filter base clean.
4. Lube filter gasket with oil and install new filter. Tighten 1/2 turn after seal contacts base. Do not over tighten.
5. Close drain cock. (all engines)
6. Fill with engine oil.
Linamar:
Add 1.8 U.S. Quarts (1.7 liters) engine oil.
Kubota:
Add 3 U.S. Quarts (2.9 liters) for Kubota gas engines.
Add 5.4 U.S. Quarts (5.1 liters) for Kubota diesel engines.
Refer to engine manual for oil specifications.
7. Run engine and check filter and drain cock for leaks.
8. Stop engine and refill to proper oil level.

NOTE:

THE USE OF ANY AIR FILTER OR OIL FILTER OTHER THAN THOSE SPECIFIED BY THE ENGINE MANUFACTURER IS NOT RECOMMENDED. IF A NON-GENUINE PART CAUSES OR SUBSTANTIALLY CONTRIBUTES TO A FAILURE, THAT FAILURE MAY NOT BE COVERED BY WARRANTY.

Air Filters

- Install filters properly, do not over tighten and deform element.

Linamar

- Keep an extra foam wrap oiled and ready - Can keep the extra foam wrap in tool box.

Kubota

- Don't over service, remove end cap only to clean out dust. Don't tap dirt out.
- Don't blow out with compressed air. Don't change filter until the engine starts to smoke.
- Check intake hoses and fittings for damage or leaking.

Oil Filters

- Use only O.E.M. Brand filters. - Some after market filters are not constructed the same.

Fuel Filters

- Use only O.E.M. brand filters
- Buy your fuel from a reputable supplier. Recommended gasoline is 87 octane. Recommended diesel fuel is No. 2. Store it properly - keep moisture out.
- Shelf life of fuel is about 3 months - gasoline and diesel.
- Store fuel in proper, clean containers.

Cooling

- Keep chaff screen clean. - Air cooled and liquid cooled.
- Keep engine block clean. Grass, dirt, misc. debris will act as an insulator.
- Do not run Linamar engine with oil filter boot removed.

- Do not pressure wash a hot or running engine.
- Keep radiators clean. - Do not use high pressure air or washers to clean. Use only low air or water pressure. Blow directly through fins and not on an angle so as not to damage or close fins.
- Use only commercial grade anti freeze (for cast iron liquid cooled engines) and deionized water in a 50/50 mix. Mix outside of engine. Don't mix Propylene Glycol and Ethylene Glycol.
- Do not remove thermostat.

Starting Tips.

- Never use starting fluid or ether as a starting aid.
- Linamar and Kubota Gas - Use choke as needed on cold engines.
- Kubota Diesel - Open throttle half and crank engine two to three seconds. Turn preheat until light goes out, or for no more than fifteen to thirty seconds, start engine. No choke or preheat is required when engine is warm.
- Ensure battery cables are clean and making good connections.
- Make sure battery is in fully charged condition.
- Do not engage starter longer than 30 seconds.
- In severe cold applications, utilize starting aids such as block heaters, etc.

Stopping the engine... Cool down procedure

- **Linamar...** Run at full throttle - No load for three to four minutes, then idle for three to four minutes and shut down.
- **Kubota...** Run at half throttle - No load for two to three minutes, then idle for one to two minutes and shut down.

ADJUSTMENTS

Throttle Adjustment:

Tension adjustment is made by simply tightening the pivot bolt in throttle lever. High and low idle speeds are adjusted by the linkage slot located under the seat for gas engines. (see Photo 11) Adjust the length of the rods and rod ends in the engine compartment for diesel engines. (see Photo 12)

ENGINE	High Idle Speed	Low Idle Speed
Linamar	3550-3600 RPM	1400 RPM
Kubota Gas	3500-3600 RPM	1400 RPM
Kubota Diesel	3200-3250 RPM	1400 RPM

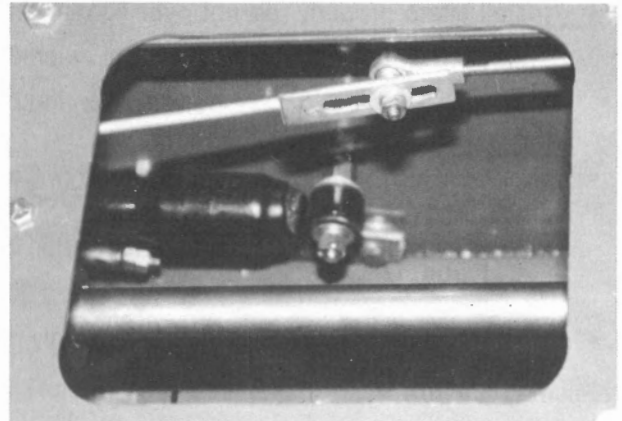

Photo 11 - Throttle Linkage
Gas engines only
(shield removed for clarity)

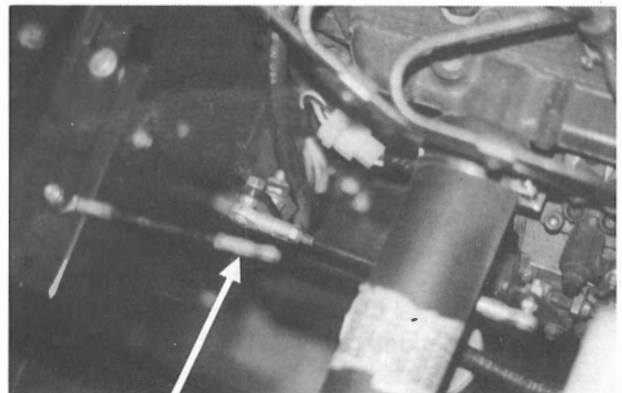

Photo 12 - Throttle Linkage
Diesel only
(hood opened for clarity)

HYDRAULIC SYSTEM

1. Keep system filled with proper fluid.
 - Check only at transaxle dip stick.
 - Check when oil is cold.
 - Use only clean containers. Keep it clean!
2. Keep oil and filter changed.
 - Initial filter change 25 hours, then oil and filter change at 50 hours..
 - Change oil and filter every 250 hours thereafter or annually. (whichever occurs first)
 - Change oil when warm (not hot).
 - Use only recommended filter and Steiner fluid or Texas Refinery Corp. 6440 Universal Torque Fluid. **Do not use motor oil or automatic transmission fluid!**
 - Check oil level after 30 minutes of operation.
 - Do not over tighten drain plug.
 - Make sure filter is tight.
 - Change hydraulic oil and filter at the first sign of abnormal hydraulic functions.
3. Check for leaks daily (Never operate a unit if a leak is detected).
 - Inspect hoses for leaks or chafing.
 - Inspect fittings and hose ends for seepage.
4. Keep power unit clean.
 - Keep auxiliary hoses and couplers clean and plugged.
 - Grass and debris will hold in heat.
 - A clean unit is easier to work on and safer to operate. And it is easier to do regular checks.

TRANSAXLE OIL CHANGE PROCEDURE

Change oil at any time contamination is suspected. Approximately 6 quarts of approved hydraulic oil are needed to change oil.

1. It is best to drain transaxle after the tractor has been thoroughly warm to insure maximum drain.
2. Remove dipstick and drain plug from transaxle.
3. Remove hydraulic filter and wipe filter base clean.
4. Lube filter gasket with oil and install new filter. Tighten 3/4 turn after gasket contacts filter base. Do not over-tighten.
5. Re-install drain plug in transaxle.
6. Fill transaxle to full mark on dipstick with approved hydraulic oil (Steiner Trans-Hydraulic Oil or Texas Refinery Corp. 6440 Universal Torque Fluid).
7. Run engine, and turn steering wheel extreme right to extreme left several times to purge all air from the circuit.
8. Drive the unit back and forth to purge air from the drive circuit.
9. Check oil level to be sure it is in the safe operating range.

NOTE:

THE USE OF ANY OIL OTHER THAN STEINER TRANS-HYDRAULIC OIL OR TEXAS REFINERY CORP. 6440 UNIVERSAL TORQUE FLUID IS NOT RECOMMENDED. IF A SUBSTITUTE OIL CAUSES OR SUBSTANTIALLY CONTRIBUTES TO A FAILURE, THAT FAILURE MAY NOT BE COVERED BY WARRANTY.

HYDROSTATIC TRANSMISSION

Neutral Linkage Adjustment:

To achieve absolute neutral it is necessary to slide the neutral centering assembly in the slotted mounting hole. Absolute neutral is when the tractor will not creep with the engine running and the Forward - Reverse pedal in neutral. The attaching bolt can be reached through the toolbox and the underseat access hole (see Photo 13). Tighten bolt securely after setting is achieved.

Pedal Position Adjustment:

Perform the neutral position adjustment before adjusting pedal position. Pedal position can be changed by adjusting the connecting link length between pedal and hydrostat control arm.

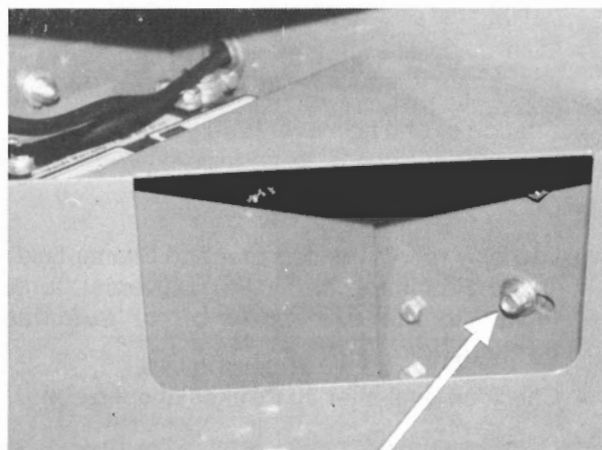

Photo 13 - Neutral Adjustment

FRAME

1. Check for loose or missing fasteners after first 10 hours. - Every 100 hours thereafter.
 - Torque all standard hardware bolts to standard grade 5 spec.
2. Do not remove guards, shields or lock straps.
 - Repair or replace any broken parts.
 - Keep frame parts clean, it makes it easier to find loose or broken parts.
 - If used in toxic areas, wash after each use - fertilizer, manure, etc., can cause corrosion of aluminum parts.

3. Keep parking brake adjusted properly.
 - Ensure that brake holds unit from creeping.
4. Lubrication
 - Grease all fittings as recommended on chart.
 - Grease PTO slider bracket pivot and apply grease to PTO slider bracket saddle and rod every 25 hours.
 - Use Chain Lube, WD40 or light motor oil to lubricate all pivot points, hood hinges, tie rod ends, etc. every 25 hours.
 - Grease drive shaft U-joints every 100 hours.

BRAKE ADJUSTMENT

Raise tractor with jack until drive wheels rotate freely.

Brake adjustment is done with the location of the brake lever on the spline of the brake cam. Loosen and remove the lever from the brake cam shaft and rotate it to the desired position and re-install. Check to be sure there is not excessive brake drag and there is adequate pedal travel to completely apply the brake.

WHEELS AND TIRES

Shift lever must be locked during operation.

- Ranges: 1-N-2, 1=Low, N=Neutral (use for emergency towing or pushing), 2=High.

Brakes: Individual wheel drum type.

- Keep them locked together unless used for turning.
- To park, push brake levers and lock by pulling brake cable.
- To unlock, push in brake lock cable knob and press both pedals to release.

Maintain proper tire pressures.

- Drive tires: 8 - 10 lbs.
- Steering tires: 14 - 16 lbs.

Ballast

- Wheel weights are available
- Rear weight bar is available.
- **DO NOT** load tires with liquid, foam, rubber, or powder ballast.
- Accumulator acts as ballast if used properly.

DO NOT use tire chains.

DO NOT use duals

Tire sealer may be used.

- Use Permatex Liquid Sealer to seal tire beads.
- Caution, some sealers use silicone which could cause rim to spin inside the tire.

Torque specs:

- Drive and steering tire wheel nuts: 85 ft lbs.
- Drive tire hub bolts: 192 inch lbs. Do in three increments.

Steering spindle hub bearings:

- Clean, repack and adjust annually.

Electric Clutch Adjustment

Clutch adjustment is required if the clutch slips. This is characterized by reduced speed of the driven attachment while engine speed remains constant. Perform the following procedure to adjust the electric clutch:

1. Stop engine and remove the ignition key. Remove the dash cover shield.
2. Insert a .012 inch feeler gauge through cutout (Drawing 1 Ref. 2) in clutch brake plate (Drawing 1 Ref. 3) and into air gap (Drawing 1 Ref. 5) between armature (Drawing 1 Ref. 4) and rotor (Drawing 1 Ref. 6). If .012 gauge is a loose fit in air gap the clutch must be adjusted. Perform the feeler gauge check at all three cutouts.
3. If necessary, tighten all three brake spring nuts (Drawing 1 Ref. 1) to reduce air gap. Tighten nuts so air gap is equal at all three cutouts.
4. After preliminary adjustment, check air gap at each cutout and repeat step 3 if necessary.
5. Repeat steps 3 and 4 until .012 inch feeler gauge is a snug fit at all three check points. Replace shield.
6. Before placing unit in service, mount an attachment, start the engine and cycle the clutch on and off 40 to 50 times to seat the clutch and brake.

(NOTE: This step should be performed each time a unit is returned to service after being out of service for more than 3 weeks.)

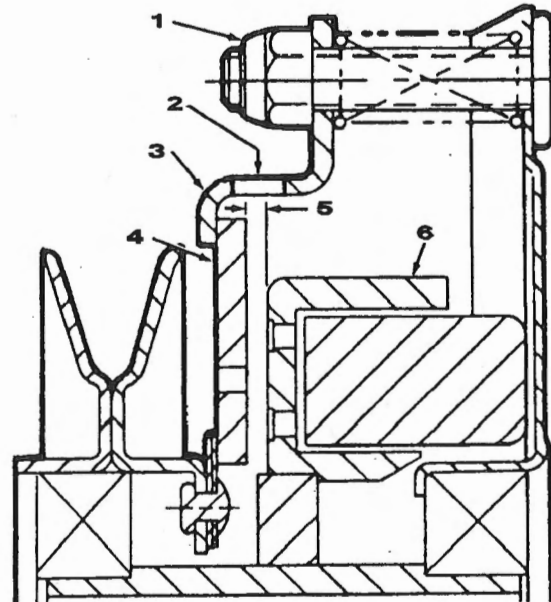

Drawing 1

Belt Size Chart for Steiner Model 230 and Common Attachments (see attachment manuals for complete listings)		
Model	Description	Part No.
	Engine Drive Pulley to Idler	81-B033
ALL	Rotary Mowers	81-A040
PB100	Power Blower	81-A040
PB200	Power Turbine Blower	81-A040
PR348	Power Box Rake	81-A043
RM674 and RM684	Reel Mower	81-A043
RS350	Rotary Sweeper	81-A040
SB348	Snowblower	81-A053
TL348	Tiller	81-A040

TROUBLE SHOOTING CHART

SYMPTOM: Engine will not turn over	
Possible Cause	Remedy
Battery dead.	Check battery, charge or replace.
F - R pedal not in Neutral	Check F-R pedal for tight or broken linkage.
Defective wiring, broken or loose connections.	Visually check, or check with test light for continuity on the circuits.
Defective starter or starter solenoid.	Check by using a jumper from the battery terminal to the solenoid terminal.
Safety switches out of adjustment.	Adjust switches so they are fully depressed.
SYMPTOM: Engine difficult to start, or runs poorly.	
Possible Cause	Remedy
Fuel valve partly closed	Open fuel valve all the way.
Fuel filter dirty.	Replace fuel filter.
Ignition system defective wires, plugs, etc. (Gas engines only.)	Check plugs, wires, etc. (Gas engines only.)
Air cleaner dirty.	Replace air cleaner element.
Water or dirt in the fuel.	Drain and refill with fresh clean fuel.
Engine running too hot.	Clean engine screen and fins on air cooled engine. Check radiator water level on water cooled engine and clean radiator screen.
Choke out of adjustment. (Gas engines only.)	Adjust choke to close properly.
Air in fuel system.	Bleed air out of fuel system.
Defective fuel pump.	Check fuel pump.

TROUBLE SHOOTING CHART

SYMPTOM: Front lift will not lift attachments	
Possible Cause	Remedy
Cylinder lift pin broken or missing	Replace pin
Oil level too low in transaxle.	Fill transaxle to level on dipstick between the two marks.
Hydraulic oil filter dirty or plugged.	Replace with Steiner approved hydraulic filter.
Engine RPM too low	Set RPM to specifications
Trying to lift while steering	Change procedure
Attachment is too heavy	Lighten attachment or set accumulator pressure
Low charge pump pressure.	See Steiner dealer for pump service.
SYMPTOM: Power steering slow and/or erratic will not steer	
Possible Cause	Remedy
Oil level too low in transaxle.	Fill transaxle to level on dipstick between the two marks.
Hydraulic oil filter dirty or plugged.	Replace with Steiner approved hydraulic filter.
Air leak in suction system, pinched hose	Repair leak or hose
Engine RPM too low	Set RPM to specifications
System overloaded or not up to operating temperature	Relieve load and warm up unit
Low charge pump pressure.	See Steiner dealer for pump service.

TROUBLE SHOOTING CHART

SYMPTOM: Excessive wheel slip, loss of traction.	
Possible Cause	Remedy
Accumulator pressure too low.	Set traction booster (accumulator pressure) according to operating instructions (Section 4, Page 4-4).
Weight distribution.	Add wheel weights.
Tire pressure too high.	Adjust tire pressures.
SYMPTOM: Implement floats or will not go down.	
Possible Cause	Remedy
Accumulator pressure too high.	Set traction booster (accumulator pressure) according to operating instructions (Section 4).
SYMPTOM: Implement drive belt slips.	
Possible Cause	Remedy
Loose drive belt.	Adjust belt tension adjustment lever one notch tighter (See Section 4, Page 4-5).
Wrong size drive belt.	Use correct belt size.
Excessive load on attachment drive system.	Check implement attachment for worn or damaged drive parts, blades, bearings, or excessive foreign material buildup.

TROUBLE SHOOTING CHART

SYMPTOM: Tractor will not move with engine running and Forward – Reverse control pedal in forward or reverse position.	
Possible Cause	Remedy
Brakes locked.	Release parking brake lock.
Oil level too low in transaxle.	Check transaxle oil level and refill to between marks on dipstick.
Hydraulic oil filter dirty or plugged.	Replace hydraulic oil filter with Steiner approved filter.
Air leak in suction line.	Check for loose fittings or damaged suction line.
Drive coupling failure.	Check drive coupling to determine if pump input shaft is turning.
Pump control linkage failure.	Check pump control linkage and repair.
Transaxle shift lever in neutral.	Check transaxle shift lever. Be sure shift lever is completely engaged.
Low charge pump pressure or faulty hydrostatic system.	See Steiner dealer for pump service.
SYMPTOM: PTO will not run.	
Possible Cause	Remedy
Operator not seated.	With Operator seated, restart PTO.
Electrical problem.	See Steiner dealer for electrical service.
Belt slipping.	Check for broken or wrong size engine drive belt.

1. Remove unit and all parts from crate.
2. Install the wheels with valve stems facing outward and tighten wheel nuts to 75 ft. lbs. Adjust tire pressures. Refer to Service Schedule in Section 5.
3. Install the seat (if removed) and connect the wiring for the seat switch. It is very important to connect this wiring for safety interlock and operator presence control.
4. Install the steering wheel (if removed) and torque the nut to 40 ft. lbs. Snap the center cover in place.
5. Check all fluid levels. Refer to Service Schedule in Section 5.
6. Visually inspect for loose bolts or fittings.
7. Start the unit and test drive to check all functions.

STATEMENT OF LIMITED WARRANTY

STEINER TURF EQUIPMENT INC. warrants its line of equipment to be free from defects in material and factory workmanship for a period of 12 months. This statement does not limit engine warranties in which the engine manufacturers carry extended time periods beyond the 12 months. Engine warranty claims will be subject to the engine manufacturer's approval.

Exception to this warranty period will be the Chipper/Shredder and Trencher which carry a 90 day warranty. Homeowner warranties will be extended to a 24 month warranty on power units only.

Replacement Parts carry a 90 day replacement warranty and are reimbursed to the dealer, net of the prompt payment. All electrical and hydraulic parts are limited by this policy and will only be covered upon approval by the service department after the inspection of the part. The installation and removal of a part will automatically place that part under the replacement parts warranty.

This guarantee is limited exclusively to equipment manufactured or supplied by STEINER TURF and is subject to the inspection and analysis by the company to conclusively identify or confirm the nature and cause of failure.

PRODUCT REGISTRATION FORM must be completely filled out, signed by the customer, and returned to STEINER TURF before any warranty claims will be considered.

STEINER TURF reserves the right to incorporate improvements in material and design of its products without notice and is not obligated to make the same improvements to equipment previously manufactured.

STEINER TURF is not obligated under any warranty different from the warranty as published above.

STEINER TURF'S RESPONSIBILITIES

STEINER TURF'S obligation under the terms of this warranty is limited to the repair, replacement or credit, at its option, of the equipment, parts or supply items that conform to this warranty.

STEINER TURF will pay for the parts and the cost of surface transportation for the parts that conform to this warranty.

DEALER'S RESPONSIBILITIES

1. Only factory-trained service personnel will be permitted to perform warranty service on STEINER TURF equipment.
2. All major warranty claims such as overhauls - rebuilds must be authorized by STEINER TURF before work is performed.
3. All replacement parts used in warranty situations must be furnished by STEINER TURF or approved by STEINER TURF service personnel. The use of non-recommended oil or parts may void the warranty.

OWNER'S RESPONSIBILITIES

The owner is obligated to operate and maintain the equipment in accordance with the recommendations published by STEINER TURF in the owner/operator's manual for the unit. The owner is responsible for the costs associated with such maintenance and operating adjustments which may be required on a regularly scheduled basis. The owner is responsible for transportation to and from the dealership or service calls made by the dealer.

CONDITIONS WHICH VOID WARRANTY

This warranty shall not apply to equipment which:

- 1. Has had repairs or modifications not authorized by STEINER TURF.
- 2. Has been subject to abuse, improper maintenance, or improper application.

WARRANTY EXCEPTIONS

This warranty does not apply to the following items:

- 1. Wear items including blades, cutting edges, spark plugs, points and condensers, belts, filters, bearings, sprockets, chains, tires, light bulbs, lubricants and fluids.
- 2. Damages to engine/drive systems caused by a lack of/ or improper lubricants and/ or fluids.
- 3. Damages to engine/drive systems caused by improper operation and/ or maintenance.

FREIGHT CARRIER DAMAGE

Claims for equipment damaged in transit should be referred to the freight carrier. Visible damage should be reported immediately, and concealed damage as soon as possible, in accordance with freight carrier regulations.



WARNING



The engine exhaust from this product contains chemicals known to the State of California to cause cancer, birth defects or other reproductive harm.

CALIFORNIA Proposition 65 Warning

Diesel engine exhaust and some of its constituents are known to the State of California to cause cancer, birth defects and other reproductive harm.